



- Heaviest screed in it's class for excellent paving quality
- High performance tractor with additional reserve capacity
- Unique Quad Auger system to pave X-tra wide
- Simplified operating concept with 2 full functional consoles
- Failsafe automatic heating control for uninterrupted paving
- Added value with premium standard features

## TECHNICAL DATA

### MASSES

Mass (tractor)	15,000 lbs
Paver weight (incl. standard screed)	19,500 lbs

### DIMENSIONS

Front ramp angle	11°
Standard Paving Width	8-15.5 ft
Transport width	8 ft
Working width, hydraulic extendable	15.50 ft
Working width, max.	18 ft
Working width, minimum (Cut Off Shoe)	1 ft

### CAPACITY

Paving thickness (max/min)	6 in / 0 in
Theoretical placement capacity	550 t/h

### MATERIAL HOPPER

Capacity	19,000 lbs
Dumping height, center	16 in
Hopper width, internal	120 in

### PROPULSION

Paving speed	140 fpm
Transport speed	3 mph

### ENGINE

Electrical system	12V
Emissions according to	EPA T4f/EU4
Engine alternator capacity	140 Amps
Fuel tank capacity	22 gal
Heating generator capacity	16 kW, 480V 3 Phase
Manufacturer/Model	Cummins QSF 3.8
Rated power, SAE J1995	120 hp (89kW) @ 2200 rpm

### UNDERCARRIAGE

Crawler length	72.0 in
Crawler width	14.0 in
Final drive	Hydrostatic with gear reducer
Type	Steel track with poly pad

### CONVEYOR

Conveyor control	Automatic with Auger control
Conveyor type	Dual slat conveyor
Conveyor width	22 in

### AUGER

Auger control	Automatically with ultrasonic sensor
Auger diameter	12 in
Extension auger	230 mm (9 in) mounted on screed extensions

Find us locally at [www.dynapac.us](http://www.dynapac.us)

We reserve the right to change specifications without notice. Photos and illustrations do not always show standard versions of machines. The above information is a general description only, all informations are supplied without liability.



- Heaviest screed in it's class for excellent paving quality
- High performance tractor with additional reserve capacity
- Unique Quad Auger system to pave X-tra wide
- Simplified operating concept with 2 full functional consoles
- Failsafe automatic heating control for uninterrupted paving
- Added value with premium standard features

## DIMENSIONS

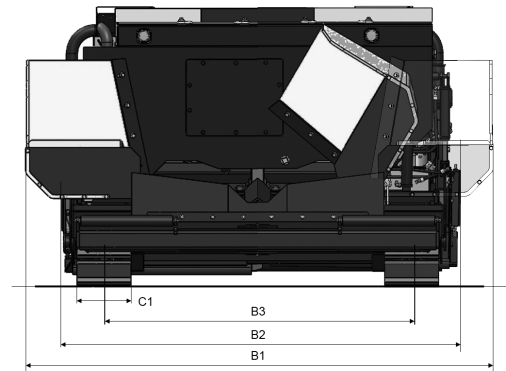
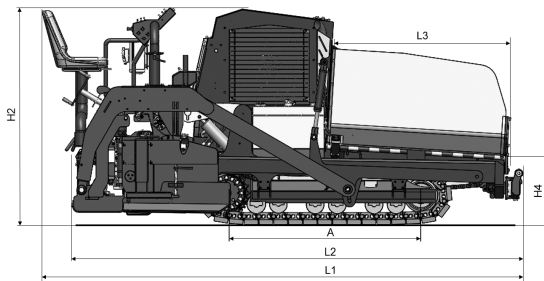

### DIMENSIONS

A. Axle track	72 in
B1. Width, max.	125 in
B2. Width, standard	102 in
B3. Width, center of tracks	76 in
C1. Track width	14 in
H2. Height, transport	71 in
H4. Dumping height	16 in
L1. Length, total	165 in
L2. Length, transport	165 in
L3. Length, hopper	65 in

### STANDARD EQUIPMENT

- LED Work Lights
- Backup Alarm & Rotating Beacon
- Reversible auger and conveyor
- Rebuildable wear resistance conveyor floor plates
- Segmented High Wear Augers
- Hydraulic Tow Point
- Screed Power Crown
- Screed Power Match height
- Ultrasonic sensors auger
- Wash down spray system
- Dual operator console with conventional electrics
- Screed ext. power slope control
- Heated end gate

### OPTIONAL EQUIPMENT

- Road Crew Kit
- 3 Man operation
- Levelling System
- Averaging Ski beam
- CutOff plates
- Screed Extension
- Truck Hitch
- Umbrella

Find us locally at [www.dynapac.us](http://www.dynapac.us)

We reserve the right to change specifications without notice. Photos and illustrations do not always show standard versions of machines. The above information is a general description only, all informations are supplied without liability.



## COMPATIBLE SCREEDS

 Suitable screeds					
Model	Basic width	Working width, hydraulic extendable	Working width, max.	Compacting elements	Heating system
Dynapac VF0816C	8 ft	15.5 ft	18 ft	Vibration	Electric

Find us locally at [www.dynapac.us](http://www.dynapac.us)

We reserve the right to change specifications without notice. Photos and illustrations do not always show standard versions of machines. The above information is a general description only, all informations are supplied without liability.